

www.esbelt.com

# Conveyor Belts

Profiles, Round & Vee Belts,  
Flat belts, Buckets.

2009 - 2010



 **esbelt**  
Conveyor belts



ISO 9001:2008

# Industrial & General Purpose Belts

Belt type		Top cover					Bottom cover					Special characteristics	
		Material	Hardness °ShA	Colour	Thickness mm	Surface	Material	Hardness °ShA	Colour	Thickness mm	Surface		
Aster	A12 G2F	PVC	55	Green 00	3,70	Pattern G2			Natural		Textured	⊕	
	A12 G2K	PVC	65	Green 00	3,70	Pattern G2	PVC	90	Green 00	0,70	Pattern K	⊕	
	A13 QF	PVC	45	Green 00	1,70	Pattern Q			Natural		Textured	⊕	
	A15 G2F	PVC	55	Black 02	3,70	Pattern G2	CR		Black 00	0,10	Impregn.	⊕ S	⚡
	A15 QF	PVC	55	Black 02	1,70	Pattern Q	CR		Black 00	0,10	Impregn.	⊕ S	⚡
	A15 W1F	PVC	65	Black 02	6,00	Pattern W1	CR		Black 00	0,10	Impregn.	⊕ S	⚡
	A20 AF	PVC	75	Green 00	1,20	Pattern A			Natural		Textured	⊕	▼
	A20 G2F	PVC	55	Green 00	3,70	Pattern G2			Natural		Textured	⊕ S	
	A24 QF	PVC	45	Red 01	4,50	Pattern Q			Natural		Textured	⊕	
A33 QF	PVC	45	Green 00	3,40	Pattern Q			Natural		Textured	⊕		
Breda	B12 UF	PU	93	Green 09	0,30	Smooth			Natural		WP	⊕	FDA ● ▼ ▽ □
	B20 UF	PU	93	Green 09	0,50	Smooth			Natural		Textured	⊕	FDA ● ▼ ▽ □
	B07 CF	PVC	82	Green 00	0,50	Smooth			Natural		Textured	⊕	▼ □
	B12 CF	PVC	82	Green 00	0,50	Smooth			Natural		Textured	⊕	▼ □
	B12 CK	PVC	82	Green 00	0,50	Smooth	PVC	90	Green 00	0,70	Pattern K	⊕	▼ □
	B20 CF	PVC	82	Green 00	1,00	Smooth			Natural		Textured	⊕	▼ □
	B20 CK	PVC	82	Green 00	1,00	Smooth	PVC	90	Green 00	0,70	Pattern K	⊕	▼ □
	B20 FF			Black 00		Textured			Natural		Textured	⊖ S ●	⚡
	B22 CF	PVC	82	Green 00	2,00	Smooth			Natural		Textured	⊕	▼ □ ■
	B23 CF	PVC	45	Green 00	3,00	Smooth			Natural		Textured	⊕	
	B25 CF	PVC	82	Green 00	1,00	Smooth			Natural		Textured	⊕	▼ □
	B30 CF	PVC	82	Green 00	2,00	Smooth			Natural		Textured	⊕	▼ □ ■
B33 CF	PVC	45	Green 00	3,00	Smooth			Natural		Textured	⊕		
Drago	D20 CC	PVC	78	Green 00	1,00	Smooth	PVC	78	Green 00	1,00	Smooth	⊕	▼ □ ☼
	D30 AR	PVC	78	Green 00	2,20	Pattern A	PVC		Green 00	0,10	Impregn.	⊕	▼ □ ■
	D30 CC	PVC	78	Green 00	2,00	Smooth	PVC	78	Green 00	1,00	Smooth	⊕	▼ □ ■ ☼
	D30 CR	PVC	78	Green 00	2,00	Smooth	PVC		Green 00	0,10	Impregn.	⊕	▼ □ ■
	D40 CC	PVC	78	Green 00	2,00	Smooth	PVC	78	Green 00	1,00	Smooth	⊕	▼ □ ■ ☼
	D81 CC	PVC	78	Green 00	1,00	Smooth	PVC	78	Green 00	1,00	Smooth	⊕	▼ □
	D90 C3R	PVC	75	Green 00	2,45	Pattern C3	hard PVC		Green 00	0,10	Impregn.	⊕	▼ □ ■
Febor	F10 NF	PVC	76	Black 04	0,50	Mat			Natural		Textured	⊕ S	
	F18 NF	PVC	76	Black 04	0,70	Mat			Natural		Textured	⊕ S	
	F15 NF	PVC	82	Black 01	0,50	Mat	CR		Black 00	0,10	Impregn.	⊕ S	⚡
	F19 NF	PVC	82	Black 01	0,90	Mat	CR		Black 00	0,10	Impregn.	⊕ S	⚡
	F20 NF	PVC	82	Black 01	1,00	Mat	CR		Black 00	0,10	Impregn.	⊕ S	⚡
	F21 NF	PVC	82	Black 01	0,90	Mat	CR		Black 00	0,10	Impregn.	⊕	⚡
	F22 FF	CR		Black 00	0,10	Impregn.	CR		Black 00	0,10	Impregn.	⊕ S ●	⚡
	F12 CF	PVC	78	Green 00	0,50	Smooth			Natural		Textured	⊕	
	F12 CK	PVC	78	Green 00	0,50	Smooth	PVC	90	Green 00	0,70	Pattern K	⊕	
	F14 CF	PVC	78	Green 00	1,00	Smooth			Natural		Textured	⊕	
	F20 CK	PVC	78	Green 00	0,70	Smooth	PVC	90	Green 00	0,70	Pattern K	⊕	
F30 CF	PVC	78	Green 00	0,70	Smooth			Natural		Textured	⊕		
F30 RR	PVC		Transp.	0,10	Impregn.	PVC		Transp.	0,10	Impregn.		●	
Hipro	H12 Y1R	HPVC	75	Green 23	0,60	Pattern Y1	CR		Black 00	0,10	Impregn.	⊕	▼ □
	H13 GR	HPVC	75	Green 23	5,50	Pattern G	CR		Black 00	0,10	Impregn.	⊕	▼ □
	H18 Y1R	HPVC	75	Green 23	0,80	Pattern Y1	CR		Black 00	0,10	Impregn.	⊕	▼ □
Keram	K40 AF	PU	93	Green 09	1,20	Pattern A			Natural		Textured	⊕	FDA ▼ ▽ □ ■ MP
	K40 RF	PVC		Black 03	0,10	Impregn.			Natural		Textured	⊖	▼ □ ■ MP
	K40 UF	PU	93	Green 09	1,00	Smooth			Natural		Textured	⊕	FDA ● ▼ ▽ □ ■ MP

CR = Conductive Resin WP = Low-capillary fabric "Water Proof"

Constant (intermittent) temperature °C	Fabrics		Belt thickness mm	Belt weight kg/m <sup>2</sup>	at 20°C		Breaking load N/mm	Working load at 1% elongation N/mm	Working load at 1,5% elongation N/mm	Max. roll width mm	Belt type	
	N° of plies	Weft			A	B						
- 5 (-15) + 80 (100)	2	Rigid	5,50	4,20	45	70	120	8	12	2000	A12 G2F	Aster
- 5 (-15) + 80 (100)	2	Rigid	6,30	5,25	70	90	120	10	15	2000	A12 G2K	
- 5 (-15) + 80 (100)	2	Rigid	3,20	3,50	45	70	120	9	13	2-3000	A13 QF	
- 10 (-15) + 80 (100)	2	Rigid	5,50	4,20	45	70	160	13	18	2000	A15 G2F	
- 10 (-15) + 80 (100)	2	Rigid	3,20	3,50	50	60	150	13	18	2-3000	A15 QF	
- 10 (-15) + 80 (100)	2	Rigid	8,75	4,80	80	100	150	13	18	1250	A15 W1F	
- 5 (-15) + 80 (100)	2	Rigid	2,90	3,20	55	80	200	14	20	3000	A20 AF	
- 5 (-15) + 80 (100)	2	Rigid	5,80	4,60	55	90	160	16	22	2000	A20 G2F	
- 5 (-15) + 80 (100)	2	Rigid	6,40	6,90	50	80	160	14	22	2000	A24 QF	
- 5 (-15) + 80 (100)	3	Rigid	6,40	7,00	150	200	300	20	28	2000	A33 QF	
- 10 (-15) + 80 (105)	2	Rigid	1,60	1,90	40	60	120	10	16	2-3000	B12 UF	Breda
- 10 (-15) + 80 (105)	2	Rigid	2,20	2,60	60	80	200	18	25	2-3000	B20 UF	
- 5 (-15) + 80 (100)	1	Rigid	1,00	1,10	10	25	60	5	7	3000	B07 CF	
- 5 (-15) + 80 (100)	2	Rigid	2,10	2,50	35	55	120	10	15	3000	B12 CF	
- 5 (-15) + 80 (100)	2	Rigid	2,70	2,95	50	50	120	7	12	2000	B12 CK	
- 5 (-15) + 80 (100)	2	Rigid	2,90	3,50	55	75	200	15	22	3000	B20 CF	
- 5 (-15) + 80 (100)	2	Rigid	3,50	4,00	70	70	140	9	15	2000	B20 CK	
- 5 (-15) + 80 (100)	2	Rigid	2,40	2,70	60	60	190	15	20	3000	B20 FF	
- 5 (-15) + 80 (100)	2	Rigid	4,00	4,80	80	100	200	17	25	3000	B22 CF	
- 5 (-15) + 80 (100)	2	Rigid	4,80	5,80	80	120	200	15	22	3000	B23 CF	
- 5 (-15) + 80 (100)	3	Rigid	4,00	4,80	100	120	275	22	30	3000	B25 CF	
- 5 (-15) + 80 (100)	3	Rigid	4,90	5,80	120	150	300	22	30	3000	B30 CF	
- 5 (-15) + 80 (100)	3	Rigid	6,00	7,00	130	200	300	20	28	3000	B33 CF	
- 15 (-25) + 80 (100)	2	Flexible	4,10	5,10	140	140	200	20	28	2000	D20 CC	Drago
- 15 (-25) + 80 (100)	3	Flexible	5,60	6,50	180	200	300	25	40	2000	D30 AR	
- 15 (-25) + 80 (100)	3	Flexible	6,20	7,70	200	250	300	30	40	2000	D30 CC	
- 15 (-25) + 80 (100)	3	Flexible	5,40	6,50	180	200	300	25	40	2000	D30 CR	
- 15 (-25) + 80 (100)	4	Flexible	7,40	9,20	300	350	400	35	50	2000	D40 CC	
- 15 (-25) + 80 (100)	3	Flexible	7,80	9,60	400	400	800	65	95	2000	D81 CC	
- 5 (-15) + 80 (100)	3	Flexible	7,00	8,00	300	380	800	55	85	3000	D90 C3R	
- 5 (-15) + 80 (100)	2	Rigid	1,90	2,20	35	55	120	10	15	3000	F10 NF	Febor
- 10 (-15) + 80 (100)	2	Rigid	2,70	3,30	60	80	160	12	18	3000	F18 NF	
- 10 (-15) + 80 (100)	2	Rigid	2,10	2,60	40	60	160	12	18	3000	F15 NF	
- 10 (-15) + 80 (100)	2	Rigid	2,50	3,00	40	60	160	15	20	3000	F19 NF	
- 10 (-15) + 80 (100)	2	Rigid	3,00	3,60	60	80	160	15	20	3000	F20 NF	
- 10 (-15) + 80 (100)	2	Flexible	2,70	3,30	55	75	200	20	30	3000	F21 NF	
- 10 (-15) + 80 (100)	2	Rigid	2,40	2,85	60	60	160	14	19	3000	F22 FF	
- 5 (-15) + 80 (100)	2	Rigid	2,00	2,40	35	55	120	10	15	3000	F12 CF	
- 5 (-15) + 80 (100)	2	Rigid	2,80	3,00	50	50	120	10	15	2000	F12 CK	
- 5 (-15) + 80 (100)	2	Rigid	2,50	2,90	40	60	120	9	14	3000	F14 CF	
- 5 (-15) + 80 (100)	2	Flexible	2,90	3,50	75	75	200	18	28	2000	F20 CK	
- 5 (-15) + 80 (100)	3	Flexible	2,90	3,50	90	140	300	30	45	2000	F30 CF	
- 5 (-10) + 80 (100)	3	Flexible	3,40	3,80	150	150	300	25	40	3000	F30 RR	
- 5 (-15) + 80 (100)	2	Rigid	2,00	2,20	25	50	120	10	15	2000	H12 Y1R	Hipro
- 5 (-15) + 80 (100)	2	Rigid	6,50	6,20	60	90	200	14	20	2000	H13 GR	
- 5 (-15) + 80 (100)	3	Rigid	3,00	3,50	50	80	180	15	22	2000	H18 Y1R	
- 10 (-15) + 80 (105)	2	Rigid	4,20	4,20	140	330	400	20	30	2000	K40 AF	Keram
- 5 (-15) + 80 (100)	2	Rigid	4,00	4,20	80	100	400	22	32	3000	K40 RF	
- 10 (-15) + 80 (105)	2	Rigid	4,00	4,20	140	330	400	22	32	2000	K40 UF	



A15 W1F: pitch 108 mm

- ⊕ Antistatic
- ⊕ Antistatic top cover
- ⊖ Antistatic bottom cover
- ⊖ Antistatic internal
- S Low noise fabric
- FDA Food quality
- Low friction coefficient
- ▼ Resistant to mineral oils and fats
- ▽ Resistant to oils and animal and vegetable fats
- ⊕ Resistant to vegetable oils and fats, and partially resistant to animal oils and fats
- ☑ Partially resistant to vegetable and animal oils and fats
- ☐ Abrasion resistant
- Cut resistant
- ⊕ ATEX certified
- ⊕ Pyrolysis test
- ⊕ Flame retardant
- MP MonoPly

# Food conveyor belts

Belt type		Top cover					Bottom cover					Special characteristics		
		Material	Hardness °ShA	Colour	Thickness mm	Surface	Material	Hardness °ShA	Colour	Thickness mm	Surface			
Aster	A10 G2F	PVC	60	White	4,00	Pattern G2			Natural		Textured	FDA		
	A21 HF	PVC	70	White	3,00	Pattern H			Natural		WP	FDA	⊖	
	A21 LF	PVC	70	White	3,50	Pattern L			Natural		WP	FDA	⊖	
	A21 ZK	PVC	70	White	2,00	Pattern Z	PVC	90	White	0,70	Pattern K	FDA	⊖	
	A26 XC	PVC	70	White	11,50	Pattern X	PVC	70	White	1,00	Smooth	FDA	⊖	
	A36 X1C	PVC	70	White	16,00	Pattern X1	PVC	78	White	1,00	Smooth	FDA	⊖	
Clina (PU)	C06 K1F	PU	86	Ocher 01	0,32	Pattern K1			Natural		WP	FDA	▽ □	
	C06 UF	PU	86	Ocher 01	0,30	Smooth			Natural		WP	FDA	▽ □	
	C07 UF	PU	86	White	0,30	Smooth			Natural		WP	FDA	▽ □	
	C07UFMT	PU	93	White	0,30	Mat			Natural		WP	FDA	● ▽ □	
	C07 UU	PU		Green 16	0,10	Impregn.	PU		Green 16	0,10	Impregn.	FDA	● ▽	
	C08 DF	PU	86	White	0,60	Pattern D	PU		Natural	0,10	Impregn.	⊕ FDA	▽ □	
	C08 UF	PU	86	White	0,40	Smooth	PU		Natural	0,10	Impregn.	⊕ FDA	▽ □	
	C08UFMT	PU	93	White	0,30	Mat			Natural		Textured	⊕ FDA ● ▽ □		
	C09 UF	PU	86	White	0,25	Smooth	PU		Natural	0,10	Impregn.	⊕ FDA	▽ □	
	C09UFMT	PU	93	White	0,25	Mat	PU		Natural	0,10	Impregn.	⊕ FDA ● ▽ □		
	C09UFMS	PU	88	White	0,30	Mat			Natural		Textured	⊕ FDA ● ▽ □		
	C10 FF			Natural		Cotton-Poly.			Natural		Cotton-Poly.	FDA ● ▽		
	C10 UF	PU	86	White	0,30	Smooth			Natural		WP	FDA	▽ □	
	C12 UF*	PU	86	White	0,30	Smooth			Natural		WP	FDA	▽ □	
C20 UF	PU	93	White	1,00	Smooth	PU		Natural	0,10	Impregn.	FDA ● ▽ □ ■			
Clina (PVC)	C07 CF	PVC	70	White	0,50	Smooth			Natural		WP	FDA	⊖	
	C07 JF	Felt		White		Felt			Natural		Textured			
	C11 FF			Natural		WP			Natural		WP	⊕ FDA ●		
	C12 AF	PVC	70	White	1,00	Pattern A			Natural		WP	FDA	⊖	
	C12 DF	PVC	70	White	0,70	Pattern D			Natural		WP	FDA	⊖	
	C12 CF	PVC	70	White	0,50	Smooth			Natural		WP	FDA	⊖	
	C13 FF			Natural		Textured			Natural		Textured	FDA ●		
	C16 FF			Natural		Cotton-Poly			Natural		Cotton-Poly	FDA ●		
	C20 CF	PVC	70	White	0,80	Smooth			Natural		WP	FDA	⊖	
	C20 CK	PVC	70	White	1,50	Smooth	PVC	90	White	0,70	Pattern K	FDA	⊖	
	C21 CF	PVC	70	White	0,80	Smooth	PU		Natural	0,10	Impregn.	FDA	⊖	
	C21 CK	PVC	70	White	0,50	Smooth	PVC	90	White	0,70	Pattern K	FDA	⊖	
	C22 CF	PVC	70	White	2,00	Smooth	PU		Natural	0,10	Impregn.	FDA	⊖	
	C30 CF	PVC	70	White	0,80	Smooth	PU		Natural	0,10	Impregn.	FDA	⊖	
C30 CK	PVC	70	White	1,50	Smooth	PVC	90	White	0,70	Pattern K	FDA	⊖		
Espot	E20 CC	PVC	73	White	1,00	Smooth	PVC	73	White	1,00	Smooth	⊕ FDA	⊖	⊗
	E30 CC	PVC	73	White	2,00	Smooth	PVC	73	White	1,00	Smooth	⊕ FDA	⊖	⊗
	E40 CC	PVC	73	White	2,00	Smooth	PVC	73	White	1,00	Smooth	⊕ FDA	⊖	⊗
	E81 CC	PVC	73	White	1,00	Smooth	PVC	73	White	1,00	Smooth	⊕ FDA	⊖	
	E90 CC	PVC	73	White	2,00	Smooth	PVC	73	White	1,00	Smooth	⊕ FDA	⊖	
Febor	F11 CF	PVC	85	White	0,50	Smooth			Natural		Textured	⊕ FDA		
	F19 CK	PVC	84	Blue 05	1,00	Smooth	PVC	90	Blue 05	0,70	Pattern K	FDA		
	F35 CC	PVC	85	White	1,00	Smooth	PVC	85	White	0,70	Smooth	⊕ FDA		
	F75 CC	PVC	85	White	1,00	Smooth	PVC	85	White	0,70	Smooth	⊕ FDA		
	F21 CC	PVC	75	White	2,00	Smooth	PVC	75	White	1,00	Smooth	⊕ FDA	□ ⊗	
	F31 CC	PVC	75	White	2,00	Smooth	PVC	75	White	1,00	Smooth	⊕ FDA	□ ⊗	
	F32 CC	PVC	75	White	2,75	Smooth	PVC	75	White	1,50	Smooth	⊕ FDA	□ ⊗	
	F41 CC	PVC	75	White	2,00	Smooth	PVC	75	White	1,00	Smooth	⊕ FDA	□ ⊗	
	F91 CC	PVC	75	White	3,00	Smooth	PVC	75	White	1,00	Smooth	⊕ FDA	□ ⊗	
Novak	N09 UF	PU	86	Blue 06	0,25	Smooth	PU		Natural	0,10	Impregn.	⊕ FDA	▽ □	
	N09 CF	PVC	70	Blue 06	0,50	Smooth			Natural		WP	FDA	⊖	
	N12 G2F	PVC	65	Blue 06	4,00	Pattern G2			Natural		Textured	⊕ FDA		
	N19 CF	PVC	70	Blue 06	0,80	Smooth			Natural		WP	FDA	⊖	
	N19 CK	PVC	70	Blue 06	1,00	Smooth	PVC	90	Blue 06	0,70	Pattern K	FDA	⊖	
	N20 CK	PVC	70	Blue 06	1,50	Smooth	PVC	90	Blue 06	0,70	Pattern K	FDA	⊖	
N30 CY	PVC	70	Blue 06	1,00	Smooth	PVC	70	Blue 06	0,50	Pattern Y	FDA	⊖		

\* PVC between plies. WP = Low-capillary fabric "Water Proof"

Constant (intermittent) temperature °C	Fabrics		Belt thickness mm	Belt weight kg/m <sup>2</sup>	at 20°C		Breaking load N/mm	Working load at 1% elongation N/mm	Working load at 1,5% elongation N/mm	Max. roll width mm	Belt type	
	Nº of plies	Weft			A	B						
- 5 (-15) + 80 (100)	2	Rigid	5,50	4,20	45	70	120	8	12	2000	A10 G2F	Aster
- 15 (-25) + 80 (100)	2	Rigid	5,00	4,80	80	130	200	14	20	2000	A21 HF	
- 15 (-25) + 80 (100)	2	Rigid	5,50	4,80	100	160	200	14	20	2000	A21 LF	
- 15 (-25) + 80 (100)	2	Flexible	4,50	4,70	80	100	200	18	28	2000	A21 ZK	
- 15 (-25) + 80 (100)	2	Flexible	14,90	7,30	150	200	550	25	55	600	A26 XC	
- 15 (-25) + 80 (100)	2	Flexible	19,50	7,30	230	280	550	25	55	800	A36 X1C	
- 10 (-15) + 90 (110)	1	Rigid	0,82	0,90	10	30	60	6	8	2000	C06 K1F	Clina (PU)
- 10 (-15) + 90 (110)	1	Rigid	0,80	0,90	10	30	60	6	8	2-3000	C06 UF	
- 10 (-15) + 90 (110)	1	Rigid	0,80	0,90	10	30	60	6	8	2-3000	C07 UF	
- 10 (-15) + 90 (110)	1	Rigid	0,80	0,90	10	30	60	6	8	2000	C07UFMT	
- 15 (-25) + 90 (110)	1	Rigid	0,50	0,35	8	8	60	5	7	3000	C07 UU	
- 10 (-15) + 90 (110)	1	Rigid	1,30	1,25	10	30	50	5	7	2000	C08 DF	
- 10 (-15) + 90 (110)	1	Rigid	1,10	1,25	10	30	50	5	7	2000	C08 UF	
- 10 (-15) + 90 (110)	1	Rigid	1,00	1,10	10	30	50	5	7	2000	C08UFMT	
- 10 (-15) + 90 (110)	2	Rigid	1,25	1,45	15	40	100	9	15	2000	C09 UF	
- 10 (-15) + 90 (110)	2	Rigid	1,25	1,45	15	40	100	9	15	2000	C09UFMT	
- 10 (-15) + 80 (100)	2	Rigid	1,30	1,40	15	40	80	6	8	3000	C09UFMS	
- 15 (-25) + 90 (110)	2	Flexible	1,40	1,25	10	10	110	7	10	2200	C10 FF	
- 10 (-15) + 90 (110)	2	Rigid	1,40	1,60	20	50	120	10	18	2000	C10 UF	
- 10 (-15) + 80 (105)	2	Rigid	1,60	1,90	40	60	120	10	16	2-3000	C12 UF*	
- 10 (-15) + 90 (110)	2	Rigid	2,80	3,20	80	100	200	18	25	2000	C20 UF	
-15 (-25) + 80 (100)	1	Rigid	1,00	1,10	10	25	60	5	7	3000	C07 CF	
5 (-15) + 80 (100)	1	Rigid	2,90	1,90	60	80	85	8	10	1800	C07 JF	
-15 (-25) + 80 (100)	2	Rigid	1,30	1,40	30	30	120	9	12	3000	C11 FF	
-15 (-25) + 80 (100)	2	Rigid	2,70	3,00	40	60	120	9	13	3000	C12 AF	
-15 (-25) + 80 (100)	2	Rigid	2,30	2,50	35	55	120	10	15	3000	C12 DF	
-15 (-25) + 80 (100)	2	Rigid	2,10	2,50	35	55	120	10	15	3000	C12 CF	
-5 (-15) + 80 (100)	2	Rigid	2,00	2,40	40	40	120	9	12	3000	C13 FF	
-5 (-15) + 80 (100)	2	Rigid	2,55	2,40	40	40	160	5	8	2100	C16 FF	
-15 (-25) + 80 (100)	2	Rigid	2,80	3,30	55	75	200	15	22	3000	C20 CF	
-15 (-25) + 80 (100)	2	Rigid	4,10	4,85	75	90	140	9	15	2000	C20 CK	
-15 (-25) + 80 (100)	2	Flexible	2,40	2,90	55	75	200	20	30	2000	C21 CF	
-15 (-25) + 80 (100)	2	Flexible	2,60	3,10	75	75	200	18	28	2000	C21 CK	
-15 (-25) + 80 (100)	2	Rigid	4,00	4,80	80	100	200	17	25	3000	C22 CF	
-15 (-25) + 80 (100)	3	Rigid	3,70	4,40	110	140	300	22	30	3000	C30 CF	
-15 (-25) + 80 (100)	3	Rigid	5,20	6,20	130	150	210	16	25	2000	C30 CK	
- 15 (-25) + 80 (100)	2	Flexible	4,10	5,00	140	140	200	20	28	2000	E20 CC	Esport
- 15 (-25) + 80 (100)	3	Flexible	6,20	7,70	200	250	300	30	40	2000	E30 CC	
- 15 (-25) + 80 (100)	4	Flexible	7,40	9,20	300	350	400	35	50	2000	E40 CC	
- 15 (-25) + 80 (100)	3	Flexible	7,80	9,60	400	400	800	65	95	2000	E81 CC	
- 15 (-25) + 80 (100)	3	Flexible	9,00	11,20	400	500	900	75	130	2000	E90 CC	
- 5 (-15) + 80 (100)	2	Rigid	2,00	2,40	35	55	120	10	15	3000	F11 CF	Febor
-15 (-25) + 80 (100)	2	Flexible	3,10	3,60	75	75	200	18	28	2000	F19 CK	
-15 (-25) + 80 (100)	4	Flexible	6,30	7,90	250	250	400	35	50	2000	F35 CC	
-15 (-25) + 80 (100)	3	Flexible	6,00	7,40	350	350	800	65	95	2000	F75 CC	
-15 (-25) + 80 (100)	2	Flexible	5,00	6,10	140	190	200	20	28	2000	F21 CC	
-15 (-25) + 80 (100)	3	Flexible	6,10	7,60	200	250	300	30	40	2000	F31 CC	
-15 (-25) + 80 (100)	3	Flexible	7,40	9,40	300	350	300	30	40	2000	F32 CC	
-15 (-25) + 80 (100)	4	Flexible	7,40	9,20	300	350	400	35	50	2000	F41 CC	
-15 (-25) + 80 (100)	3	Flexible	9,60	11,90	400	500	900	75	130	2000	F91 CC	
-10 (-15) + 90 (110)	2	Rigid	1,25	1,35	15	40	100	9	15	2000	N09 UF	Novak
-15 (-25) + 80 (100)	2	Rigid	2,10	2,50	35	55	120	10	15	3000	N09 CF	
-5 (-15) + 80 (100)	2	Rigid	5,50	4,20	50	80	120	9	13	2000	N12 G2F	
-15 (-25) + 80 (100)	2	Rigid	2,80	3,30	55	75	200	15	22	3000	N19 CF	
-15 (-25) + 80 (100)	2	Flexible	3,10	3,60	75	75	200	18	28	2000	N19 CK	
-15 (-25) + 80 (100)	2	Rigid	4,10	4,85	75	90	140	9	15	2000	N20 CK	
-15 (-25) + 80 (100)	3	Rigid	4,30	5,00	140	140	210	16	25	2000	N30 CY	



A36 X1C: also available in 500 and 600 mm.

- ⊕ Antistatic
- ⊕ Antistatic top cover
- ⊖ Antistatic bottom cover
- ⊖ Antistatic internal
- S Low noise fabric
- FDA Food quality
- Low friction coefficient
- ▼ Resistant to mineral oils and fats
- ▽ Resistant to oils and animal and vegetable fats
- ⊕ Resistant to vegetable oils and fats, and partially resistant to animal oils and fats
- ⊕ Partially resistant to vegetable and animal oils and fats
- Abrasion resistant
- Cut resistant
- ⊕ ATEX certified
- ⊕ Pyrolysis test
- ⊕ Flame retardant
- MP MonoPly

# Food conveyor belts

Belt type	Top cover						Bottom cover					Special characteristics
	Material	Hardness °ShA	Colour	Thickness mm	Surface	Material	Hardness °ShA	Colour	Thickness mm	Surface		
<b>Poler</b>	<b>P08 EF</b>	Polyester	93	Natural	0,30	Mat			Natural		Textured	☉ FDA ● ▼ ☒ ☐ ☉
	<b>P18 EF</b>	Polyester	93	Natural	0,35	Mat			Natural		Textured	☉ FDA ● ▼ ☒ ☐ ☉
	<b>P18 T1F</b>	Polyester	93	Natural	2,10	Pattern T1			Natural		Textured	☉ FDA ▼ ☒ ☐ ☉
<b>Verna</b>	<b>V12 PF</b>	Polyolef.	91	Transp.	0,50	Mat			Natural		Textured	FDA ☉
	<b>V18 PF</b>	Polyolef.	91	Transp.	0,50	Mat	Polyolef.		Natural	0,10	Impregn.	☉ FDA ☉
	<b>V18 PP</b>	Polyolef.	91	Transp.	0,50	Smooth	Polyolef.		Transp.	0,20	Smooth	FDA ☉
	<b>V18 T1F</b>	Polyolef.	91	Transp.	2,10	Pattern T1	Polyolef.		Natural	0,10	Impregn.	☉ FDA ☉
	<b>V18 TF</b>	Polyolef.	91	Transp.	2,00	Pattern T	Polyolef.		Natural	0,10	Impregn.	☉ FDA ☉
	<b>V20 PF</b>	Polyolef.	92	Transp.	0,30	Mat	Polyolef.		Natural	0,10	Impregn.	☉ FDA ● ☐ ☉
	<b>V30 PF</b>	Polyolef.	92	Transp.	0,30	Mat	Polyolef.		Natural	0,10	Impregn.	☉ FDA ● ☐ ☉
	<b>V08 SF</b>	Silicone	40	White	0,30	Smooth	PU		Natural	0,10	Impregn.	☉ FDA
	<b>V12 SX*</b>	Silicone	40	Transp.	0,30	Smooth			Natural		Textured	FDA

## Food Regulations

The general aim is to ensure safe food, protecting human health and the environment. Food regulations affect in varying degrees manufacturers of chemical substances, manufacturers of food contact materials such as belting, and food manufacturers. The regulations imply restrictions that foster the development of new products and procedures. In developed areas regulations phase out of the food contact materials market products, manufacturers and importers that do not comply. Obtaining compliance is often a complex and time consuming process; also some regulations, notoriously **Directive 2002/72/EC**, are regularly subjected to amendments, clarifications and extensions. Therefore published catalogues are not the best source for updated information.

### FDA

An FDA product is a product approved by the USA Food and Drug Administration, whose broad aim is to ensure safe food. The FDA does not test products itself but rather reviews the results and product information of accepted laboratories. Approval processes of the FDA are dependant upon the risks that every product category poses to consumers. Title 21 of the Code of Federal Regulations lists the substances permitted in food contact materials, stipulated by the executive Departments and Agencies of the USA Federal Government.

### HACCP

To ensure safe food, traditionally manufacturers have used spot checks of manufacturing conditions and random sampling of final products. The Hazard Analysis and Critical Control Point system is a more efficient, preventive health and safety methodology that directly affects food producers. It aims at evaluating eventual health hazards and establishing adequate monitoring and corrective actions at explicitly identified critical points of food manufacturing, packaging and transport processes. The FDA and European regulatory agencies are developing specific procedures to establish HACCP as the standard food quality system throughout all areas of the food industry. As such, it has little to do with the technical characteristics of belt types: if appropriately cleaned and replaced, any food quality belt might be applied in HACCP processes. However consensus is developing that only antibacterial belts might be said to assist food manufacturers in the implementation of the HACCP quality system.

### REACH

It involves the Registration, Evaluation and Authorisation of Chemical substances in a central public data base run by the European Chemicals Agency. Entered into force on 1 June 2007 but its provisions are phased-in over 11 years, so benefits will come gradually. However as of 2009 all substances available in the European Union must at least be pre-registered. It directly affects manufacturers and importers of chemical substances, not conveyor manufacturers. **Esbelt** requires and monitors that all of its raw materials suppliers comply, and consults the data base to look for hazard information.

### ATEX

With preventing aims, the European ATEX Directive applies to components of machinery, such as belting, working in potentially explosive environments. Explosions may occur in processes with dust, milling, drying, conveyance and storage in silos, most particularly if bucket elevators are involved. Due to this, the **esbelt** ATEX certified belts are all of the Espot, Drago and Febor series. Within the different existing ATEX categories the **esbelt** belts are ATEX Category 2, meaning compliance with Directive 94/9/EC, which applies to non electrical components of machinery for use in potentially explosive atmospheres.

## Directive 2002/72/EC and Regulation 1935/2004

2002/72/EC is the European quasi equivalent to the USA FDA, this normative establishes a list of products that are acceptable as food contact materials. It directly affects belt manufacturers. The product listing under FDA and under 2002/72/EC are not automatically the same. Under this Directive, belts cannot release their chemical components into carried foodstuff above a global limit of 10 mg/dm<sup>2</sup> of surface area. It also establishes some maximum migration limits for specific substances used in the belt chemical formulae. The fact that migration is contingent upon time of contact and temperature adds ambiguity to the meaning of the Directive as an intrinsic belt characteristic. **Esbelt's** general criteria is to qualify a belt as 2002/72/EC if it complies after 2 hours under 40°C. but targeted time and temperatures are adapted on a case by case basis for specialized belting considering type of food product to be carried and environmental conditions at plant manufacturing sites. **1935/2004** is a regulation covering all types of food contact materials stating that they cannot transfer their constituents into foodstuffs in quantities which could: a) endanger human health, b) bring about an unacceptable change in the composition of the foodstuffs, or c) deteriorate the organoleptic characteristics thereof. Since the meaning of endanger, unacceptable and deteriorate cannot be quantified this regulation, contrary to 2002/72/EC and its ulterior developments, provides only a very general and uncertain regulation framework.

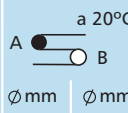
Constant (intermittent) temperature °C	Fabrics		Belt thickness mm	Belt weight kg/m <sup>2</sup>			Breaking load N/mm	Working load at 1% elongation N/mm	Working load at 1.5% elongation N/mm	Max. roll width mm	Belt type	
	N° of plies	Weft			∅ mm	∅ mm					P	V
-20 (-30) + 100 (120)	1	Rigid	1,00	1,10	10	30	60	5	7	2000	P08 EF	Poler
-20 (-30) + 100 (120)	2	Flexible	2,40	2,50	40	100	200	12	20	2000	P18 EF	
-20 (-30) + 100 (120)	2	Flexible	4,50	3,30	120	140	200	12	20	2000	P18 T1F	
-15 (-25) + 35 (55)	2	Rigid	1,80	1,75	50	70	110	10	15	2000	V12 PF	Verna
-15 (-25) + 35 (55)	2	Flexible	2,50	2,40	60	80	200	12	20	2-3000	V18 PF	
-15 (-25) + 35 (55)	2	Flexible	2,70	2,80	80	80	200	14	20	2000	V18 PP	
-15 (-25) + 35 (55)	2	Flexible	4,60	2,90	95	140	200	12	18	2000	V18 T1F	
-15 (-25) + 35 (55)	2	Flexible	4,50	2,90	95	140	200	12	18	2000	V18 TF	
-10 (-20) + 50 (70)	2	Rigid	2,50	2,40	65	80	180	7	13	2-3000	V20 PF	
-10 (-20) + 50 (70)	3	Rigid	3,60	3,40	150	200	300	16	25	2-3000	V30 PF	
-25 (-35) + 150 (170)	1	Rigid	1,00	1,00	8	20	50	5	7	2000	V08 SF	
-15 (-25) + 80 (110)	2	Rigid	1,75	2,00	35	55	120	10	15	2-3000	V12 SX*	

\* PVC between plies.



- ⊕ Antistatic
- ⊕ Antistatic top cover
- ⊕ Antistatic bottom cover
- ⊖ Antistatic internal
- S Low noise fabric
- FDA Food quality
- Low friction coefficient
- ▼ Resistant to mineral oils and fats
- ▽ Resistant to oils and animal and vegetable fats
- ⊙ Resistant to vegetable oils and fats, and partially resistant to animal oils and fats
- ⊚ Partially resistant to vegetable and animal oils and fats
- Abrasion resistant
- Cut resistant
- ⊕ ATEX certified
- ⊕ Pyrolysis test
- ⊕ Flame retardant
- MP MonoPly

## Skirts

Type	Material	Manufacturing width mm	Thickness mm	Hardness °ShA	Weight Kg/m <sup>2</sup>	Available colours
V15 PL	Polyolefine	1850	2,10	91	1,10	Transparent
NF 104	PVC	100	4,00	70	0,50*	White, Green 00, Blue 06
UNSS60	PU	62	2,30	85	0,177*	White, Green 09, Blue 06
UNRS85	PU	87	3,30	85	0,365*	White, Green 09, Blue 06
B07 CC	PVC	2000	1,30	82	1,60	Green 00

\* Weight in Kg/m

## More usual Patterns

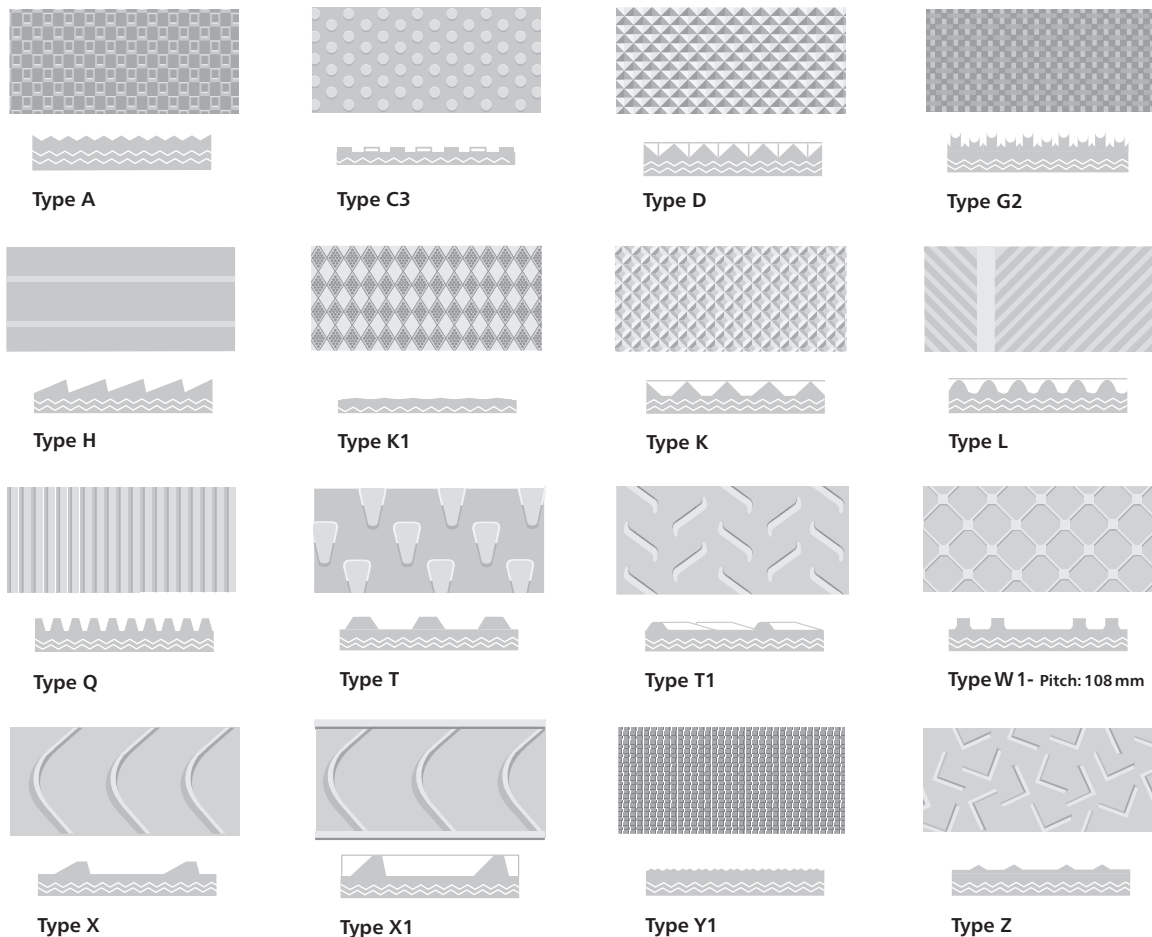

# esbelt series



## Aster series

**Food.** White, FDA food-quality.  
**Industry.** Green and black. Belts with an embossed cover for lifting or lowering packaged or bulk products.



## Breda series

**Industry.** High resistance to abrasion, chemical products and mineral oils. Excellent performance under difficult working conditions.



## Clina series

**Food belts.** Excellent resistance to vegetable oils and animal fats. Non-toxic. PVC and PU.



## Drago series

**Industry.** Resistant to cuts, abrasion and mineral oils. For roller, troughed conveyors and bucket elevators. Conveyance of clay, chemical fertilizers and grain materials.



## Espot series

**Food.** Excellent resistance to vegetable oils and fats. For roller troughed conveyors and bucket elevators. Conveyance of organic materials: food, seeds, compound foddere, waste.

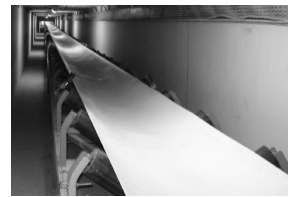

## Febor series

**Industry.** Green – Packaged or grain products free of oils or fats. Black – Flame retardant belts, airports, post office and logistics centres.  
**Food.** White and blue - FDA food-quality, flame-retardant, resistant to abrasion. Sugar, carrots and other vegetables.



## Hipro series

**Industry.** Excellent resistance to abrasion, better than some elastomers, highly antistatic, fusion splice. Conveyance and processing of cardboard, paper and other abrasive materials.



## Keram series

**Industry.** Highly resistant to cuts and mineral oils. Automobile industry (cutting and stamping of metal).



## Novak series

**Food.** PVC and PU blue belts. Excellent resistance to vegetable oils and animal fats.

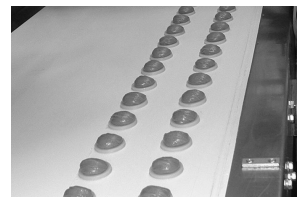

## X series

**Food and knife-edge applications.** White PU belts, with smooth, homogenous covers. Excellent longitudinal flexibility. Resistant to oils and fats.



## Poler series

**Tobacco and Food belts.** Polyester belts are compliant with Pyrolysis test. They work extremely well at high temperatures.



## Verna series

**Tobacco and Food belts.** Polyolefine belts are compliant with Pyrolysis test. Silicone belts for conveying very sticky products.

## Some esbelt specialities



### Belts for the Grape Harvest

Blue, food-quality belt, highly rigid and excellent traction with transversal and longitudinal profiles.



### Sealing Edges

This protects the side edges of the belt from bacteria.

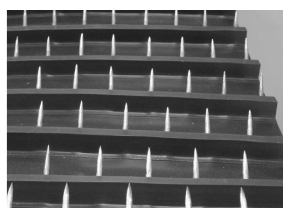

### Belts for "Monoblock" Aprons

Robust, anti-static belts with thermowelded profiles in which U-shaped nails are attached.

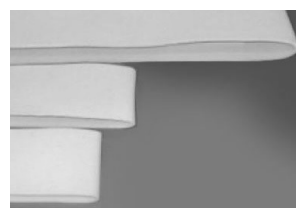

### Tubul Series - trully endless. seamless - sleeves

100% wool felt endless belts (no splice or seam) Baking and confectionery.



### Curved Belts

Belts with a flexible weft to make curved belts with a single splice.



# Cleats (flights)

## for conveyor belting

Inclined conveyors occasionally require belts with profiles or cleats (flights) on the carrying surface. These prevent slippage of the conveyed material and increases the belt capacity.

The type and height of the most suitable cleat (flight) is determined according to the characteristics of the conveyed material and the inclination of the conveyor. Optimum conveying capacity can be achieved up to angles of 70° by this means.

Notched PVC trapezoidal tracking guides can be supplied; this increases belt flexibility and when fitted to the underside of the belt can reduce the minimum pulley diameter by 10%.

**esbelt** cleats (flights) are oil and fat resistant.

Examples of possible cleat (flight) arrangements are as follows:

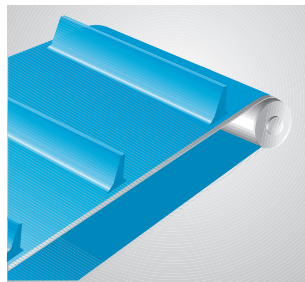

Single transverse cleat

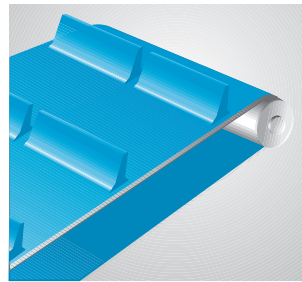

Double transverse cleat

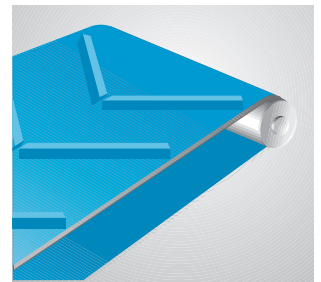

Herringbone "V" pattern

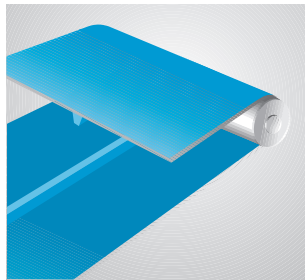

Inner tracking guide

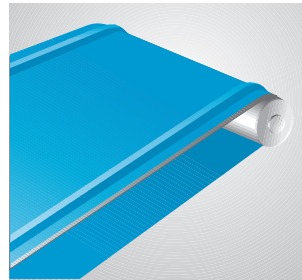

Retaining sidewalls

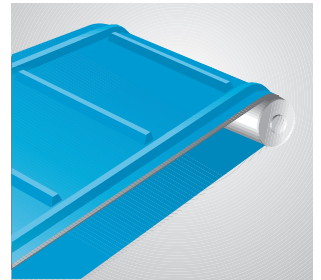

Single transverse cleat with retaining sidewalls

## Arrangement of cleats in open "V" pattern (herringbone)

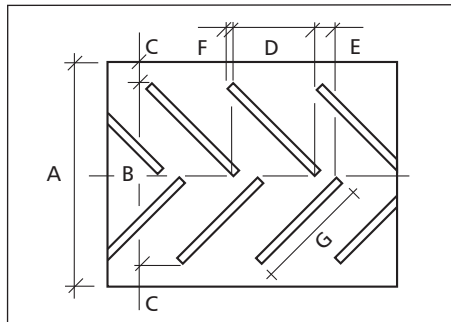

Dimensions mm							
<b>A</b>	400	500	600	650	800	1000	1200
<b>B</b>	300	400	450	480	600	800	900
<b>C</b>	50	50	75	85	100	100	150
<b>D</b>	180	205	210	225	286	348	390
<b>E</b>	20	20	20	20	20	20	20
<b>F</b>	18	18	24	30	50	60	60
<b>G</b>	250	300	325	350	450	550	600

## Recommendations for profile attachment

Profile attachment is best carried out on **2 or more ply belts**.





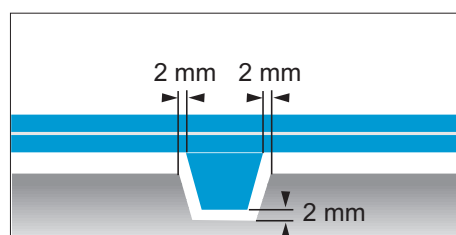



Minimum covers thickness for profile type are given below.

To obtain good results with a **tracking guide**, the grooves in the pulleys, rollers and slider beds must be larger than the tracking guide which is welded to the belt.

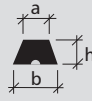

Material and type of profile		Minimum cover thickness
<b>PVC</b>	short fingers	0,3 mm
	height 20 and 30 mm	0,5 mm
	reinforced profiles	0,8 mm
	height 40, 50, 60 mm and types NE.012 and NE.C14	0,8 mm
	height 70, 80 mm and types NE.K16, NE.015 and fingers	1 mm
<b>PU</b>	all types	0,3 mm
<b>TPE</b>		
<b>PO</b>	all types	0,5 mm

# Cleats (flights)

Section	Type	Dimensions			Material (1)	Weight g/m	Transverse		Longitudinal		Possible positioning (3)
		b mm	h mm	a mm			minimum pitch mm	minimum $\phi$ (2) mm	minimum $\phi$ mm (2)	bottom side	
	NE.008	8	8		PVC	75	28	100	60	110	T - G - L - V
	NE.012	12	12		PVC	175	32	100	80	120	
	PE.008	8	8		PO	56	28	100			T - V
	PE.012	12	12		PO	133	32	100			
	NE.015	20	15		PVC	330			200	250	G - L
	NA.X04-62	6	4	4,2	PVC	23			25	30	G - L
	NE.Y05-62	8	5	4,4	PVC	40	28	50	50	60	T - G - L - V
	NE.Z06-62	10	6	5,6		60	30	70	70	80	
	NE.A08-62	13	8	7,2		100	33	90	90	100	
	NE.B11-62	17	11	9,0		180	37	100	100	120	
	NE.C14-62	22	14	11,8		300	42	150	150	180	
	NE.K16-70	30	16	18,4		470	50	250	250	250	
	UE.Z06	10	6	5,6	PU	59	30	70	70	80	T - G - L - V
	UE.A08	13	8	7,2		98	33	90	90	100	
	UE.B11	17	11	9,0		170	37	100	100	120	
	PE.Z06	10	6	5,6	PO	46	30	100			T - V
	PE.A08	13	8	7,2		75	33	110			
	PE.B11	17	11	9,0		130	37	120			
EE.Z06	10	6	5,6	TPE	56	30	80		80	T - G - L - V	
EE.A08	13	8	7,2		95	33	90		100		
EE.B11	17	11	9,0		167	37	100		120		
	DE.Y05-62	8	4,5	4,0	PVC	30			35		G
	DE.Z06-62	10	5,5	5,0		45			50		
	DE.A08-62	13	7,5	7,0		75			70		
	DE.B11-62	17	10,5	9,0		140			80		
	DE.C14-62	22	14,0	11,8		255			130		
	DE.K16-70	30	16,0	18,0		385			175		
	NV.020-70	25	20		PVC	290		120			T
	NV.030-70	25	30			370		120			
	NV.040-70	25	40			450	45	120			
	NV.050-70	25	50			600		120			
	NV.060-70	25	60			700		150			
	NL.030-70	25	30			PVC	430	50	120		
NL.040-70	25	40		550	50		120				
NL.050-70	25	50		700	50		120				
NL.060-70	25	60		780	50		150				
NL.070-70	40	70		1240	130		170				
NL.080-70	40	80		1400	130		180				
	UV.020	10	20		PU	140		40			T
	UV.030	10	30			190	30	45			
	UV.050	10	50			330		50			
	PV.020	10	20		PO	95					T
	PV.030	10	30			135	30	100			
	PV.050	10	50			235					
	EV.020	10	20		TPE	130					T
	EV.030	10	30			170	30	80			
	EV.050	10	50			300					
	UL.030	10	30		PU	215		45			T
	UL.050	10	50			320	30	50			
	PL.030	10	30		PO	155					T
	PL.050	10	50			225	30	100			
	EL.030	10	30		TPE	210					T
	EL.050	10	50			310	30	80			
	NM.040-62	45	40		soft PVC	640		120			T
	NM.060-62	55	60		soft PVC	1120		150			
	NQ.040-62	42	40		soft PVC	665		120			T
	NQ.060-62	60	60			1150		150			
	NQ.070-62	60	70			1300		170			

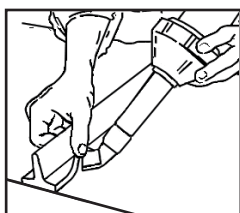

(2) The minimum recommended diameters given are for normal working conditions, at 20°C. Lower temperatures require greater diameters.

(3) Profile positioning:  
T - Transversal, G - Inner tracking guide, L - Lateral retaining wall, V - V-shaped.

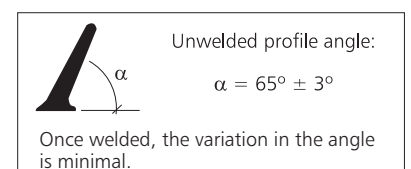

(1)	Material	Colour	Specials characteristics	Hardness	Temperature °C
PVC	PVC	Green 00 - White - Blue 06	FDA, antistatic, oil resistant	70° ShA	-10 + 80
soft PVC	PVC	Green 00 - White - Blue 06	FDA, antistatic, oil resistant	62° ShA	-15 + 80
PU	Polyurethane	Green 09 - White - Blue 06	FDA, oil resistant	85° ShA	-10 + 100
PO	Polyolefine	Transparent	FDA, oil resistant	90° ShA	-10 + 50
TPE	Polyester	Natural	FDA, oil resistant	40° ShD	-20 + 105

## Special profiles

### Fingers and Short Fingers

As an alternative of cleats, **esbelt** provides "Finger" profiles. Specially indicated for conveying fruit on inclined sections (preventing sharp knocks that might damage the appearance) and frozen food products (the cylindrical structure prevents the frozen product from sticking to the belt).

**Esbelt** offers "Short Fingers" used mainly in harvesters of thin-skinned (apples, nectarines, peaches, pears, etc.) and the conveyance and selection of asparagus.

Profile	Height mm	Hardness °ShA	Colour	Minimum $\phi$ mm
Fingers	92	80	White and Green	100
Short Fingers	25	67		60

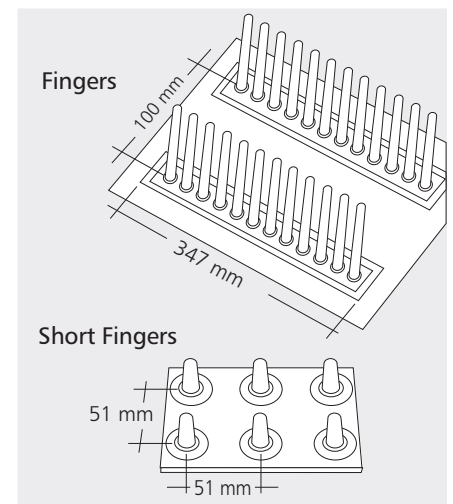

### Reinforced straight profile

**Esbelt** offers reinforced PVC profiles in 4 different heights, specially designed for applications involving difficult conditions; in general all applications in which the profiles undergo impact on receiving or conveying material. Excellent resistance to ripping and cutting. Strong and long-lasting that increase transverse rigidity of the belt, producing greater stability on the conveyor.

Profile	Dimensions		Transverse attachment		Length mm	Colour
	b mm	h mm	Minimum pitch mm	Minimum $\phi$ (2) mm		
FZNR30	50	30	70	120	1600 mm strips	Blue 06, White and Green 00
FZNR50		50				
FZNR70		70				
FZNR100		100				

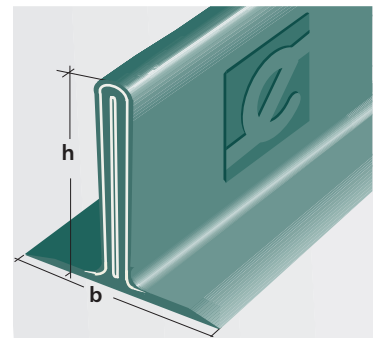

### Belt support on the return side

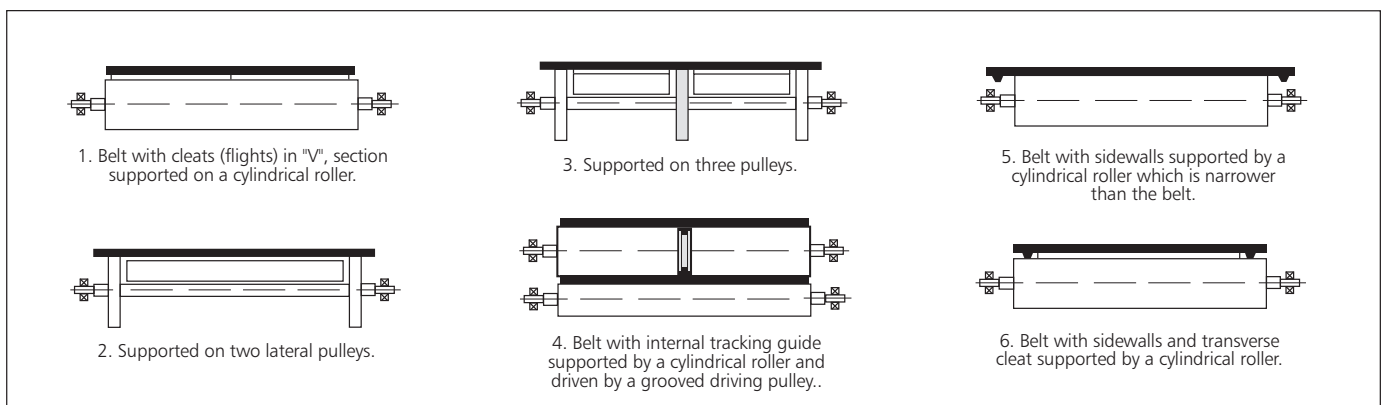

# Runers

## PVC "Runer" - without base -

Profile welded directly onto belt.

### FRRS type

- With internal polyester reinforcement: Resistant to the drum pressure at the inflections and on the return side.
- Recommended for particularly long and wide conveyors or for conveyors with inflections.

PVC	hF mm height	aF mm width	cF mm pitch	Minimum diameter mm	Thickness mm
FRRS35	35	48	55	80	5
FRRS40	40	48	55	100	5
FRRS45	45	48	55	100	5
FRRS50	50	48	55	120	5
FRRS55	55	48	55	120	5
FRRS60	60	48	55	140	5
FRRS65	65	48	55	140	5
FRRS70	70	48	55	160	5
FRRS75	75	48	55	160	5
FRRS80	80	48	55	180	5
FRRS85	85	48	55	180	5
FRRS90	90	48	55	200	5
FRRS95	95	48	55	220	5
FRRS100	100	48	55	220	5

### FSSS type

- With internal polyester reinforcement.
- Recommended for straight or lighter conveyors.

PVC	hF mm height	aF mm width	cF mm pitch	Minimum diameter mm	Thickness mm
FSSS35	35	30	30	80	3,5
FSSS40	40	30	30	90	3,5
FSSS45	45	30	30	90	3,5
FSSS50	50	30	30	100	3,5
FSSS55	55	30	30	100	3,5
FSSS60	60	30	30	110	3,5
FSSS65	65	30	30	120	3,5

### FNSS type

- No internal reinforcement: Developed for use in conveyors with extremely small pulley diameters.
- Recommended for small straight conveyors (no inflections).

PVC	hF mm height	aF mm width	cF mm pitch	Minimum diameter mm	Thickness mm
FNSS35	35	35	30	40	4
FNSS45	45	35	30	50	4
FNSS55	55	35	30	60	4

## PU "Runer" - without base -

Profile welded directly onto the belt, without internal reinforcement.

PU	hF mm height	aF mm width	cF mm pitch	Minimum diameter mm	Thickness mm
UNSS35	35	28	30	50	2,3
UNSS40	40	28	30	60	2,3
UNSS45	45	28	30	65	2,3
UNSS50	50	28	30	75	2,3
UNSS55	55	28	30	80	2,3
UNSS60	60	28	30	90	2,3
UNSS65	65	28	30	95	2,3

Layout of transverse cleat and "Runer" without base.

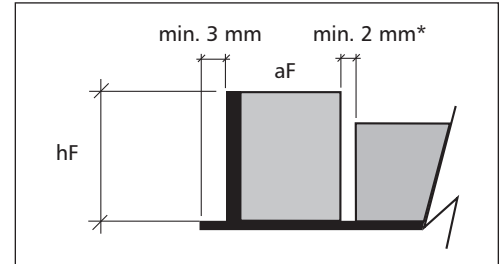

\*When a cleat is type NL.070 or NL.080, the minimum distance of 2 mm will be increased to 5 mm.

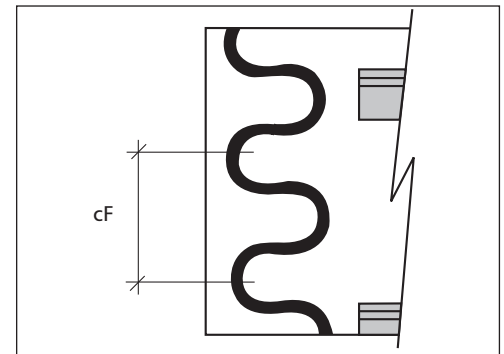

The distance between the transverse cleats should be a multiple of the - cF - pitch, if it is to coincide with the undulation of the "Runer".

The minimum length for endless belts with the Runer profile is:

- 2,000 mm with PVC Runer
- 2,500 mm with PU Runer

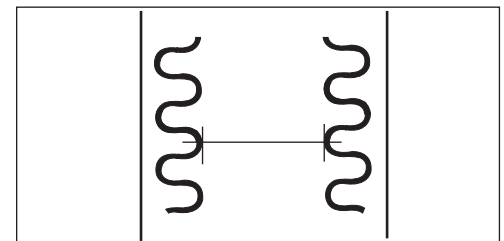

The minimum distance between 2 Runer should be:

- 100 mm with PVC Runers
- 120 mm with PU Runers

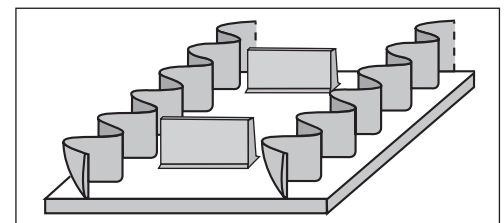

The length of the transverse cleats should be a multiple of 25 mm.

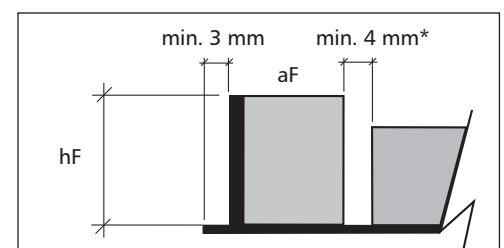

\*When the cleat and Runer are PU the minimum distance between them will be 4 mm.

## "Runer" -with base-

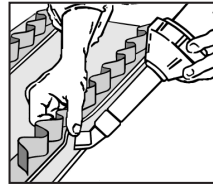
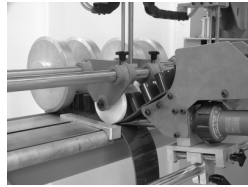

Profile with base for welding by hand with the Leister or using our LSM 1200R machine.

Outline of "Runer" with base.

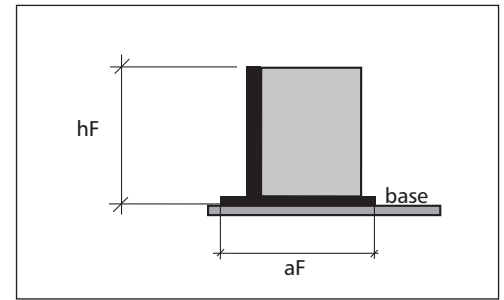

### PVC

#### FSRC type

PU	hF mm height	aF mm width	cF mm pitch	Minimum diameter mm	Thickness mm
FSRC35	35	55	55	80	3,5
FSRC55	55	55	55	120	3,5
FSRC85	85	55	55	180	3,5

Comments: Wave width = 45 mm  
Thickness base = 3.5 mm

### PU

#### UNSM type

PU	hF mm height	aF mm width	cF mm pitch	Minimum diameter mm	Thickness mm
UNSM35	35	44	30	70	2,3
UNSM55	55	48	30	100	2,3

Comments: Wave width = 28 mm  
Thickness base = 3.3 mm

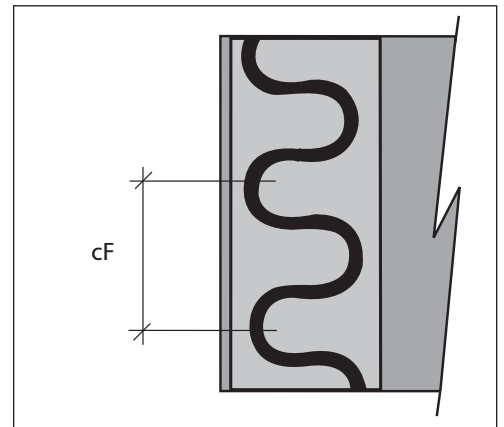

All these profiles are available in two different qualities:

- **White:** Non-toxic, FDA, suitable for using with foodstuffs.
- **Green:** Suitable for all uses that do not require food quality belts, except green PU, which is FDA.

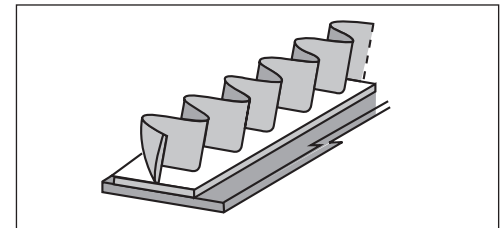

## Recommendations for Runer attachment

In order to produce a good weld for the Runer, esbelt recommends certain minimum belt cover thicknesses, depending on the type and height of the Runer being attached.

The table gives the minimum cover thicknesses for the type of Runer.

Material and type of Runer	Maximum Runer height	Minimum cover thickness
PVC (FRR, FSS and FNS)	55 mm	≥0,50 mm
PVC (FRR, FSS)	from 60 mm to 75 mm	≥0,80 mm
PVC (FRR)	from 80 mm	≥1,50 mm
PU	all types	≥0,30 mm
With base PVC and PU (FSRC and UNSM)	all types	≥0,80 mm

### General outline of nomenclature. Explanation of codes:

FSRC55B	1° Type of material	F PVC U PU
FSRC55B	2° Reinforcement	R Fabric with high transversal rigidity S Fabric with standard transversal rigidity N Not reinforced
FSRC55B	3° Pitch	S 30 mm R 55 mm
FSRC55B	4° Base	S Without base C With thin base (PVC=3.5 mm and PU=2.3 mm) M With thick base (PVC=5 mm and PU=3.3 mm)
FSRC55B	5°/6° Runer height (mm)	From 35 mm to 100 mm
FSRC55B	7° Colour	B White V Green

# PU Round & Vee belts

## Main characteristics

- Easy and fast splicing. - Resistance to abrasion. - Resistance to oils and fats. - Resistance to a wide range of chemical products.  
 - High tensile strength. - Vibration absorption. - Low noise functioning - Easy to clean. - Easy to store due to special packaging.

**Friction coefficient:** Smooth finish: 0,4 to 0,8 (depending on hardness). - Rough finish: 0,3.

**Maximum recommended speed:** 15 m/s

**Recommended operating temperatures:** -20°C to +50°C (permanent) / -40°C to +80°C (momentaneous).

**Assembly:** Belt connection by thermoplastic fusion. To calculate the final length of the belt, pretension will have to be considered.  
 Pretension: - Non-reinforced belts: maximum 8% (depending on hardness). - Aramid reinforced belts: <1%.

Esbelt has all of the necessary handling and assembling machinery to guarantee excellent finished products.

## Round belts

Section	Hardness 88° ShA Smooth green 14	Diameter (d) mm	Roll length m	Weight g/m	Min. pulley diameter mm	
	RS88L03	3	100	9	25	
	RS88L04	4	100	15	40	
	RS88L05	5	100	24	50	
	RS88L06	6	100	34	60	
	RS88L07	7	100	46	60	
	RS88L08	8	100	60	80	
	RS88L10	10	50	94	100	
	RS88L12	12	50	135	120	
	RS88L15	15	50	212	150	
	<b>Rough</b>					
	RS88R03	3	100	9	25	25
	RS88R04	4	100	15	40	40
	RS88R05	5	100	24	50	50
	RS88R06	6	100	34	60	60
	RS88R07	7	100	46	60	60
RS88R08	8	100	60	80	80	
RS88R10	10	50	94	100	100	
RS88R12	12	50	135	120	120	
RS88R15	15	50	212	150	150	

## Round belts with Aramid reinforcement

Section	Hardness 92° ShA Smooth yellow 00	Diameter (d) mm	Roll length m	Weight g/m	Min. pulley diameter mm	
	RK92L08	8	100	60	85	
	RK92LW6	9,5	50	85	100	
	RK92LW8	12,5	50	145	130	
	RK92L15	15	50	212	155	
	RK92L18	18	50	305	185	
	<b>Hardness 88° ShA Rough green 14</b>					
	RK88R08	8	100	60	80	80
	RK88R10	10	50	94	100	100
	RK88R12	12	50	135	120	120
	RK88R15	15	50	212	150	150

## Ridge top belts

Section	Hardness 88° ShA Green 14	Dimensions			Roll length m	Weight g/m	Min. pulley diameter mm	
		b mm	h mm	c mm				
	PS88LOA	13	8	7	50	150	130	
	PS88LOB	17	11	9	50	255	180	
	PS88LOC	22	15	10	50	410	230	
	<b>Hardness 92° ShA Yellow 00</b>							
	PS92LOB	17	11	9	50	255	265	
	PS92LOC	22	15	10	50	410	340	

## Ridge top belts with Aramid reinforcement

Section	Hardness 88° ShA Green 14	Dimensions			Roll length m	Weight g/m	Min. pulley diameter mm
		b mm	h mm	c mm			
	PK88LOA	13	8	7	50	145	130
	PK88LOB	17	11	9	50	245	180
	PK88LOC	22	15	10	50	390	230

## Trapezoidal Vee belts

Section	Hardness 88° ShA Green 14	Dimensions		Roll length m	Weight g/m	Min. pulley diameter mm	
		b mm	h mm				
	TS88L0Z	10	6	50	60	70	
	TS88L0A	13	8	50	98	90	
	TS88L0B	17	11	50	173	115	
	TS88L0C	22	14	50	286	160	
	Hardness 92° ShA Yellow 00						
	TS92L0Z	10	6	50	60	80	
	TS92L0A	13	8	50	98	100	
	TS92L0B	17	11	50	173	130	
	TS92L0C	22	14	50	286	180	

## Trapezoidal Vee belts with Aramid reinforcement

Section	Hardness 88° ShA Green 14	Dimensions		Roll length m	Weight g/m	Min. pulley diameter mm
		b mm	h mm			
	TK88L0A	13	8	50	98	90
	TK88L0B	17	11	50	170	115
	TK88L0C	22	14	50	276	160

## Trapezoidal Vee belts with PVC rough top cover

Section	Hardness 88° ShA Green 14	Dimensions		Roll length m	Weight g/m	Min. pulley diameter mm
		b mm	h mm			
	TS88G0Z	10	10	50	95	80
	TS88G0A	13	12	50	132	100
	TS88G0B	17	15	50	218	120
	TS88G0C	22	18	50	346	180

## Trapezoidal Vee belts with smooth top cover

Section	Hardness 88° ShA Green 14	Dimensions		Roll length m	Weight g/m	Min. pulley diameter mm
		b mm	h mm			
	TS88C0Z	10	9	50	113	80
	TS88C0A	13	11	50	154	100
	TS88C0B	17	14	50	248	120
	TS88C0C	22	17	50	385	180

## Polyester belts FDA quality

Section	Hardness 55° ShD Natural 00	Diameter (d) mm	Roll length m	Weight g/m	Min. pulley diameter mm
	RSE55LW6	9,5	100	85	190
	RSE55LW8	12,5	100	150	250

## PE guides

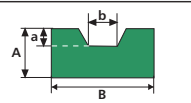
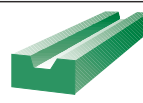
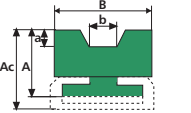
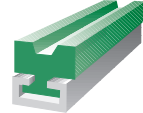
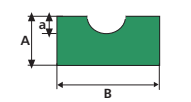
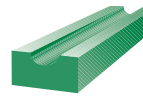
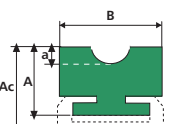
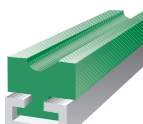
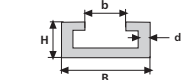
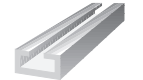
PE GUIDES - PE-1000 - FOR TRAPEZOIDAL VEE BELTS**		Dimensions mm								
		Type	Trapezoidal belt	B	A	b	a	Ac		
		GP100 Z	Z	20	10	6,50	3	-		
		GP100 A	A	20	12	8,00	5	-		
		GP100 E	E	25	12	10,0	5	-		
		GP100 B	B	30	15	10,5	8	-		
		GP100 C	C	35	20	13,5	11	-		
		GP100 D	D	40	25	19,0	13	-		
				GP100 ZC	Z	20	15	6,50	3	17
				GP100 AC	A	20	15	8,00	5	17
				GP100 EC	E	25	20	10,0	5	24
				GP100 BC	B	30	20	10,5	8	24
GP100 CC	C			35	25	13,5	11	32		
GP100 DC	D			40	30	19,0	13	35		
PE GUIDES - PE-1000 - FOR ROUND BELTS**		Dimensions mm								
		Type	Belt Ø	B	A	a	Ac			
		GP100 4	4	15	10	2,0	-			
		GP100 5	5	15	10	2,5	-			
		GP100 6	6	20	10	3,0	-			
		GP100 8	8	20	10	4,0	-			
		GP100 10	10	25	12	5,0	-			
		GP100 12	12	25	12	6,0	-			
		GP100 15	15	25	15	7,5	-			
		GP100 18	18	30	20	9,0	-			
		GP100 20	20	30	20	10,0	-			
				GP100 4C	4	20	10	2,0	14	
GP100 5C	5			20	10	2,5	14			
GP100 6C	6			20	10	3,0	14			
GP100 8C	8			20	10	4,0	14			
GP100 10C	10			25	15	5,0	18			
GP100 12C	12			25	15	6,0	18			
GP100 15C	15			25	20	7,5	24			
GP100 18C	18			28	20	9,0	24			
GP100 20C	20			28	20	10,0	24			
				GALVANIZED STEEL CHANNEL		Dimensions mm				
		B	H	b	d					
		C02VZ	20	10	10	1,5				
		C03VZ	28	12	14	2,0				
		C05VZ	38	18	22	3,5				

\*\* Supplied in 2-m strips. For other lengths, please consult.

To be mounted on the galvanized steel channel

# Toptrans. Transmission and process belts.

Leather	Sector	Type	Colour		Material		Thickness mm	
			Top surface	Drive surface	Top surface	Drive surface	Top surface	Drive surface
	Transmission <small>DIRTY AND DUSTY APPLICATIONS</small>	LF 10	Black 80	Grey 80	Nylon fabric	Leather	0,30	1,60
LF 14		Black 80	Grey 80	Nylon fabric	Leather	0,30	1,80	
LF 20		Black 80	Grey 80	Nylon fabric	Leather	0,30	1,80	
LF 25		Black 80	Grey 80	Nylon fabric	Leather	0,30	2,00	
LF 30		Black 80	Grey 80	Nylon fabric	Leather	0,30	2,00	
LF 40		Black 80	Grey 80	Nylon fabric	Leather	0,30	2,00	
LF 54		Black 80	Grey 80	Nylon fabric	Leather	0,30	2,20	
LF 80		Black 80	Grey 80	Nylon fabric	Leather	0,30	2,20	
LL 10		Grey 80	Grey 80	Leather	Leather	1,60	1,60	
LL 14		Grey 80	Grey 80	Leather	Leather	1,60	1,60	
LL 20		Grey 80	Grey 80	Leather	Leather	1,80	1,80	
LL 25		Grey 80	Grey 80	Leather	Leather	2,00	2,00	
LL 30		Grey 80	Grey 80	Leather	Leather	2,00	2,00	
LL 40		Grey 80	Grey 80	Leather	Leather	2,00	2,00	

Elastomer and Fabric	Sector	Type	Colour		Material		Thickness mm	
			Top surface	Drive surface	Top surface	Drive surface	Top surface	Drive surface
	Graphic Sector	EE 04	Green 83	Green 83	NBR	NBR	0,60	0,60
EE 06		Green 83	Green 83	NBR	NBR	0,60	0,60	
FE 06		Green 83	Black 80	NBR	Nylon fabric	0,50	0,35	
FE 10		Green 83	Black 80	NBR	Nylon fabric	0,60	0,30	
FF 06		Green 81	Green 81	Nylon fabric	Nylon fabric	0,30	0,30	
FF 10N		Black 80	Black 80	Nylon fabric	Nylon fabric	0,30	0,30	
FF 20N		Black 80	Black 80	Nylon fabric	Nylon fabric	0,30	0,30	
FE 10/2		Green 83	Black 80	NBR	Nylon fabric	1,20	0,30	
FE 14/3		Green 83	Black 80	NBR	Nylon fabric	2,10	0,30	
FE 14/4		Green 83	Black 80	NBR	Nylon fabric	2,70	0,30	
EE 10/3		Green 83	Green 83	NBR	NBR	1,20	1,20	
EE 10/4		Green 83	Green 83	NBR	NBR	1,70	1,70	
EE 14/5		Green 83	Green 83	NBR	NBR	2,10	2,10	
EE 14/6		Green 83	Green 83	NBR	NBR	2,70	2,70	
Tangential	FC 04	Natural 80	Green 81	Mixed fabric	Nylon fabric	0,30	0,30	
	FC 06	Natural 80	Green 81	Mixed fabric	Nylon fabric	0,30	0,30	
	FC 04H	Ocher 80	Green 81	Mixed fabric	Rubberized fabric	0,30	0,35	
	EE10SS	Black 81	Black 81	XNBR	XNBR	0,75	0,75	
	EE20SS	Black 81	Black 81	XNBR	XNBR	0,75	0,75	
	EE 10	Green 83	Green 83	XNBR	XNBR	0,70	0,70	
	EE 14	Green 83	Green 83	XNBR	XNBR	0,70	0,70	
	EE 20	Green 83	Green 83	XNBR	XNBR	0,70	0,70	
	EE 25	Green 83	Green 83	XNBR	XNBR	0,70	0,70	
	EE 30	Green 83	Green 83	XNBR	XNBR	0,70	0,70	
EE 33	Green 83	Green 83	XNBR	XNBR	0,70	0,70		
Transmission	EF 06	Black 80	Green 83	Nylon fabric	NBR	0,35	0,50	
	EF 10	Black 80	Green 83	Nylon fabric	NBR	0,30	0,70	
	EF 14	Black 80	Green 83	Nylon fabric	NBR	0,30	0,70	
	EF 20	Black 80	Black 81	Nylon fabric	XNBR	0,30	0,70	
	EF 25	Black 80	Black 81	Nylon fabric	XNBR	0,30	0,70	
	EF 30	Black 80	Black 81	Nylon fabric	XNBR	0,30	0,70	
	EF 40	Black 80	Black 81	Nylon fabric	XNBR	0,30	0,70	
	EF 54	Black 80	Black 81	Nylon fabric	XNBR	0,30	0,70	

NR: Natural rubber. NBR: Nitrile rubber. XNBR: Carboxilated nitrile rubber.

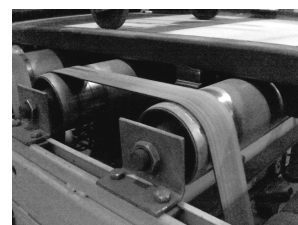
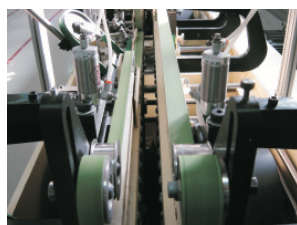



Total weight Kg/m <sup>2</sup>	Thickness mm	Shaft load at 1% elongation N/mm	Tensile strength N/mm	Elongation at break %	Minimum Pulley Ø mm	Type	Applications
2,25	2,40	10	225	22	40	LF 10	Transmissions in two pulley drive systems in dirty and dusty environments.
2,60	2,80	14	315	22	60	LF 14	
3,05	3,35	20	450	22	90	LF 20	
3,05	3,55	25	560	22	120	LF 25	
3,35	3,80	30	625	22	200	LF 30	
4,20	4,30	40	900	22	280	LF 40	
5,00	5,25	54	1215	22	380	LF 54	
6,90	7,00	80	1800	22	560	LF 80	
3,05	3,90	10	225	22	40	LL 10	Multi pulley drive transmission in dirty and dusty environments.
3,90	4,10	14	315	22	60	LL 14	
4,10	4,60	20	450	22	90	LL 20	
4,25	5,25	25	560	22	120	LL 25	
4,70	5,50	30	675	22	200	LL 30	
5,50	6,00	40	900	22	280	LL 40	

Total weight Kg/m <sup>2</sup>	Thickness mm	Shaft load at 1% elongation N/mm	Tensile strength N/mm	Elongation at break %	Minimum Pulley Ø mm	Type	Applications
1,69	1,40	4	90	22	20	EE 04	Light transmissions, controller belts in cross cutters and feeders.
1,90	1,55	6	135	22	25	EE 06	
1,30	1,25	6	135	22	20	FE 06	General use in paper folding, transferring, offset and rotary printing.
1,30	1,25	6	135	22	20	FE 10	
0,80	0,95	6	135	22	20	FF 06	Feeder belts in offset printing and PE bag machines.
0,95	1,10	10	225	22	25	FF 10N	Process belts in applications where very high abrasion occurs in the carrying surface.
1,50	1,60	20	450	22	70	FF 20N	
2,20	2,00	10	225	22	35	FE 10/2	
3,55	3,15	14	315	22	40	FE 14/3	
4,30	3,70	14	315	22	40	FE 14/4	
3,20	2,90	10	225	22	30	EE 10/3	Box folding belts in folder-gluer
4,70	3,90	10	225	22	30	EE 10/4	
5,90	4,95	14	315	22	50	EE 14/5	
7,40	6,10	14	315	22	50	EE 14/6	
0,65	0,80	4	90	22	15	FC 04	Spindle tapes in textile industries.
0,80	0,95	6	135	22	20	FC 06	
0,55	0,65	3	70	22	15	FC 04H	
2,40	2,00	10	225	22	35	EE10SS	Tangential belts in textile industry.
2,95	2,50	20	450	22	70	EE20SS	
2,25	1,90	10	225	22	35	EE 10	Tangential belts in textile industry. Transmission in multi pulley drives.
2,50	2,10	14	315	22	60	EE 14	
2,85	2,40	20	450	22	70	EE 20	
3,10	2,65	25	560	22	100	EE 25	
3,40	2,90	30	675	22	120	EE 30	
3,70	3,15	33	740	22	140	EE 33	
1,30	1,25	6	135	22	25	EF 06	
1,60	1,50	10	225	22	30	EF 10	
1,85	1,70	14	315	22	50	EF 14	
2,20	2,00	20	450	22	70	EF 20	
2,50	2,25	25	560	22	100	EF 25	
2,65	2,50	30	675	22	120	EF 30	
3,30	3,00	40	900	22	280	EF 40	
4,10	3,70	54	1215	22	380	EF 54	

Manufacturing width: 500 - 520 mm

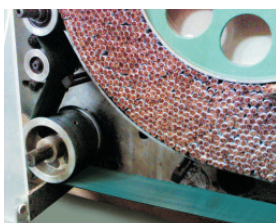

# Buckets

## Thermoplastic buckets for elevators

The most important components of an elevator are the buckets, which should have properties matching the material carried and a suitable shape for ease of unloading.

**esbelt** buckets have been designed to solve the problems currently encountered in the use of metal buckets.

**esbelt** buckets: general features:

- Functional design with rounded, smooth, non-stick inside walls facilitating the easy unloading of any powder or granulated product, thereby affording high speed performance.
- Minimum weight, since their synthetic resin fabrication makes them 70% lighter than iron buckets.
- They are rust free and resistant to oils, fats and aggressive chemicals.
- Being non-toxic and physiologically neutral, they are specially suited for foodstuff applications.
- Their elasticity permits recovery from impact and the bucket breaks before the belt in case of accidental jamming.
- Recessed holes for use with flat head bolts.

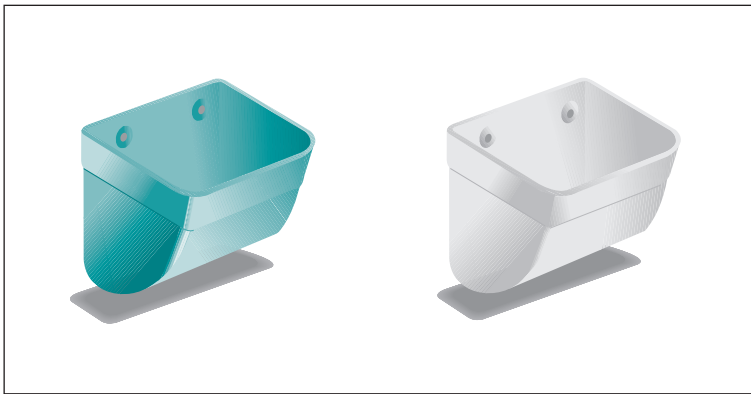

### Belt types for elevators

**Drago 30 CR - 30 CC - 40 CC - 81 CC:** Grain products mixed with mineral oils, coal, limestone, clay, chemical products, cereal grains in general (e.g. wheat, barley), soaps, etc.

**Espot 30 CC - 40 CC - 81 CC - 90 CC:** Foodstuffs, oleaginous products, soya, fodder, flour, sugar, etc.

**Febor 31 CC - 32 CC - 41 CC:** Abrasive products (sugar, salt and similar).

**Febor 35 CC - 75 CC:** Non oily food products (coffee, flour,...).

## Technical data and dimensions

The buckets are secured to the belt by means of special bolts with a wide flat head, concave washer and nut.

The hole to be made in the belt for securing the buckets is of the same diameter as the bolt.

Bolts should be checked periodically for tightness, after 100 hours of operation.

The load per bolt should not exceed 50 or 60 N.

In elevators it is very important to have the buckets loaded from a hopper which is located above the lower pulley or take-up.

"Dredging" of the buckets at the bottom of the elevator must be avoided. Such interference significantly increases the load on the belt and can reduce belt life.

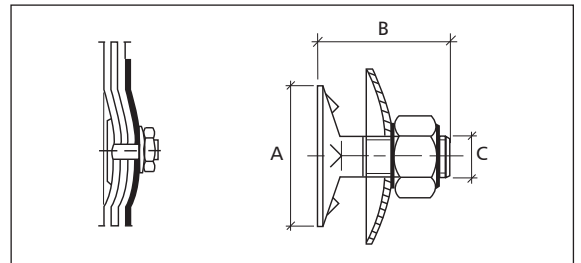

Bucket securing bolt

Flat head, with attachment bosses for belt, together with nut and domed washer

Type	A mm	B mm	C mm
M6 x 25	20	25	6
M8 x 30	28	30	8
M10 x 40	28	40	10

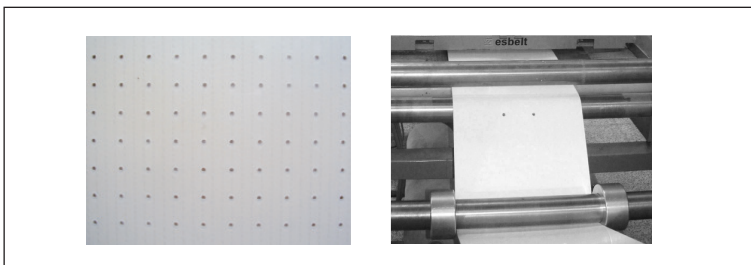

## Perforated Belts

Perforated belts may be supplied according to plans, both for holding elevator buckets and for other applications (suction, removal of liquids, etc.)

## Neucan Buckets

(Hardness 62° ShD)

**Polyethylene material. White.**

Maximum service temperature 60°C.

For use with moderately abrasive powders and granular products, flours, tobacco, fruit, animal feeds, powdered phosphates and urea; foodstuffs in general, chemicals, moist and sticky materials, etc.,

Type	A mm	B mm	C mm	D mm	E mm	Ø mm holes	n° holes	capacity l	weight gr
100	106	49	91	89	45	7	2	0,20	55
120	126	63	105	105	55	7	2	0,30	105
140	145	80	111	120	63	7	2	0,50	118
160	169	98	123	132	68	7	2	0,75	152
180	184	104	137	138	75	7	2	1,10	201
200	202	117	147	140	70	9	2	1,19	250
230	237	75	157	152	82	10	3	1,50	290
250	258	78	159	164	82	11	3	1,99	360
300	305	100	178	180	98	11	3	2,90	485
315	320	110	190	195	103	11	3	3,36	625

## Vercan Buckets

(Hardness 72° ShD)

**Polyamide material. White and green. Antistatics.**

Maximum service temperature 110°C.

For use with small or medium size granular abrasive materials, rice, sugar, cereals, granulated feeds, cement, clay, active chemicals, detergents, fertilizers, salt, etc.

Type	A mm	B mm	C mm	D mm	E mm	Ø mm holes	n° holes	capacity l	weight gr
100	107	50	90	90	47	7	2	0,24	74
120	129	64	106	106	58	7	2	0,41	140
140	145	81	113	120	64	7	2	0,53	155
160	170	98	125	132	69	7	2	0,79	194
180	190	105	137	140	78	7	2	1,14	255
200	205	119	147	142	74	9	2	1,23	317
230	237	75	157	152	85	10	3	1,70	375
250	262	79	161	165	87	11	3	2,17	475
300	305	100	178	180	98	11	3	2,90	610
315	328	111	190	195	108	11	3	3,36	785

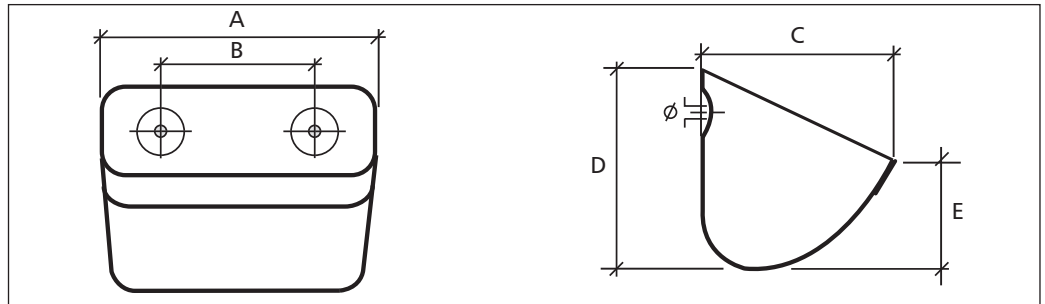

## Web Site

**Esbelt** provides a website that includes constantly updated information on our products (technical specifications, splicing instructions, applications in different sectors, and more), as well as a virtual office open 24 hours a day, to produce immediate and personalised automatic quotes, with help and interactive drawings.

- Product Search
- Product Technical Specifications
- Technical Information
- Auto Quotes
- Order Creation and Tracking
- Product Application
- Auto Digital Catalogue

The screenshot shows the Esbelt website interface. At the top, there are language options: English, Español, Deutsch, Français. Below that is a navigation bar with links for Products, Applications, Library, About Esbelt, and Contact Us. The main content area features a 'Products' menu with categories: Conveyor Belts, Transmission Belts, Thermoweldable Belts, Machinery, and Other Products. A large image shows a colorful, patterned conveyor belt. Below the image, there are two sections: 'Esbelt Products' and 'Esbelt Company'. The 'Esbelt Products' section lists 'Conveyor Belts' (PVC, Polyurethane, Polyester, Polyolefine and Silicone, 1 to 6-ply belts, covering all applications) and 'Transmission Belts' (Elastomer, leather, and fabric transmission and transport belts covering all applications). The 'Esbelt Company' section states: 'Esbelt manufactures and markets its thermoplastic conveyor belts (PVC - polyurethane - polyester - polyolefin and silicone), transmission flat belts (rubber and elastomer - leather and textile), thermoweldable round and V belts for conveyance, as well as several conveyor belt accessories (buckets - profiles and fasteners for mechanical splices) and conveyor belts machinery.'

## Machinery for Handling Conveyor Belts.

**Esbelt** offers its clients all the necessary elements for handling and installing belts, as well as the accessories required to guarantee the best possible quality of finish and to increase productivity of distributors' workshops.

Easy-to-handle **portable slitter and automatic slitter**. Both designed for cutting belts lengthways. Maximum width 2,150 mm.

**Ply separator** for highly accurate separation of the ends of 2 and 3-ply belts.

Semi-automatic hydraulically operated **finger-cutting machine**, designed for cutting fingers in the ends of belts for splicing. Working width 1,370 mm.

### Longitudinal and runer with base welder.

A pneumatically operated machine for hot-air welding on belts with a maximum width of 1,200 mm. We also have a welder just for longitudinal profiles.

**Presses** for vulcanising belts of different widths (600, 1100 and 1600 mm), providing a magnificent finish on splices.

**Edge-sealing Kit** for conveyor belts.

Tool-kit for splicing round and vee belts and different handling tools for improving workshop tasks.

## Machinery for Handling Flat Belts.

300 and 500-mm circular **slitters**, which cut up to a thickness of 7 mm.

**Skiver machine** developed for shaving the ends of belts to be spliced.

Portable **presses** for splicing belts of different widths (30, 50, 100 and 300 mm).



**Esbelt Group companies:**

### Esbelt, S.A.

Provença, 385  
08025 Barcelona  
Spain  
Tel. +34-93 207 33 11  
Fax +34-93 207 13 63  
www.esbelt.com  
esbelt@esbelt.com

### Esbelt CSY Co., Ltd.

No. 20, Chuangxin Rd, 653100  
Yuxi City, Yunnan Province  
People's Republic of China  
Tel. +86 877 2661979  
Fax +86 877 2661979  
www.esbelt.com.cn  
esbelt@esbelt.com.cn

### Esbelt GmbH

Habichtweg 2  
41468 Neuss  
Germany  
Tel. +49-2131 9203-0  
Fax +49-2131 9203-33  
www.esbelt.de  
info@esbelt.de

### Esbelt Trading Inc.

7 Winter Forest Court  
O'Fallon, MO 63366  
USA  
Tel. +636 294 2267  
Fax +636 294 2268  
www.esbelt.us  
esbelt@esbelt.us

### Esbelt SAS

Parc d'activités de Taure  
31880 La Salvétat St-Gilles  
France  
Tel. +33-5 61 06 89 10  
Fax +33-5 61 06 89 11  
www.esbelt.fr  
esbelt@esbelt.fr

### Esbelt ApS

Cikorievej 23  
DK-5220 Odense SØ  
Denmark  
Tel. +45 661 26209  
Fax +45 661 26219  
www.esbelt.dk  
esbelt@esbelt.dk

### E-plast, s.r.o.

Nam. Miru 9  
330 02 Dysina  
Czech Republic  
Tel. +420-377 946 077  
Fax +420-377 946 078  
www.e-plast.cz  
e-plast@e-plast.cz

### Omnibelt Service, S.L.

C/ Indústria s/n - P. I. Les Vives  
08295 Sant Vicenç de Castellat  
Barcelona - Spain  
Tel. +34 93 833 3556  
Fax +34 93 833 3557  
www.omnibelt.com  
omnibelt@omnibelt.com

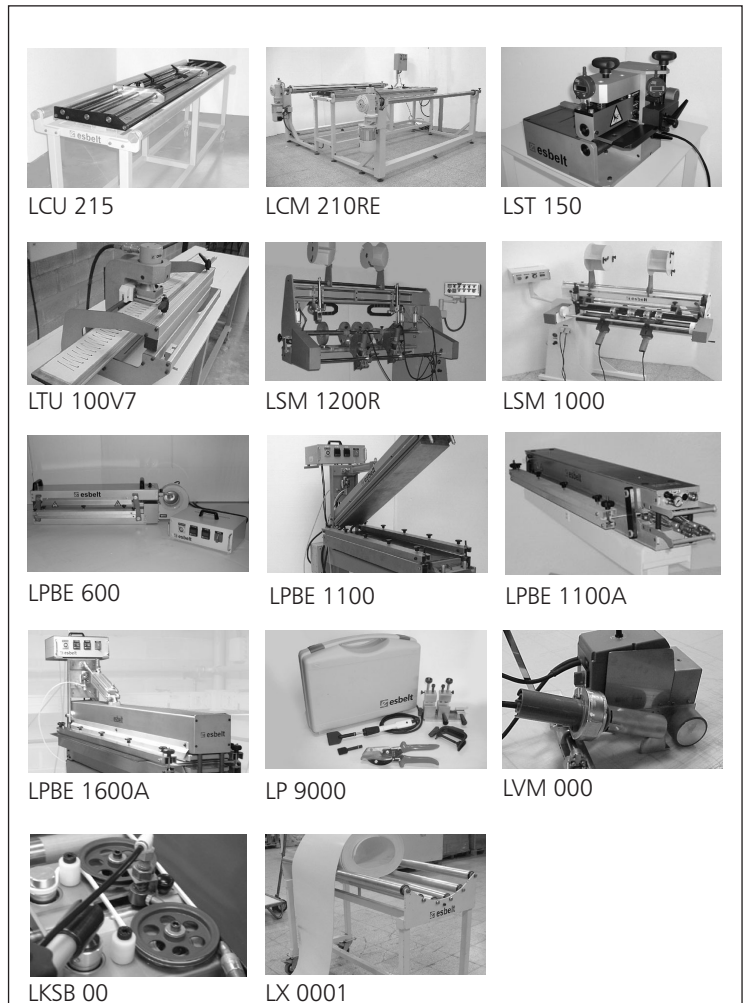

LCU 215

LCM 210RE

LST 150

LTU 100V7

LSM 1200R

LSM 1000

LPBE 600

LPBE 1100

LPBE 1100A

LPBE 1600A

LP 9000

LVM 000

LKSB 00

LX 0001

LCCB500

LCCB300

LBCE300

LPCE300

LPCZ50

LPCZ30